

# Sercos makes waves

A plant to generate waves under controlled conditions uses 72 drives – operated in clock-synchronous mode and arranged in single clusters, each with own Sercos master and eight servo drives.

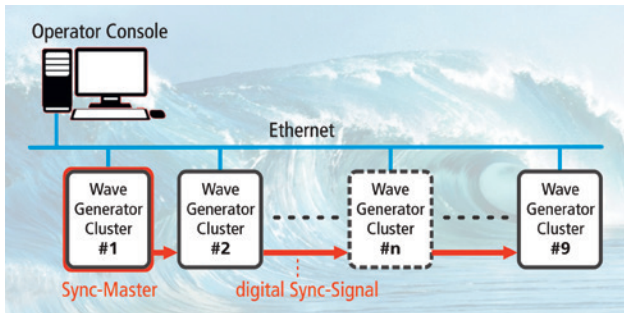

Picture 1: Plant structure with nine drive clusters

The plant equipped by Akamina Technologies simulates sea waves in a water basin. The simulation has high demands on precision of height and frequency of the waves as well as on their reproducibility. The hereto necessary precise motion of the wave boards used for the creation and active absorption of waves is reached by the clock-synchronous operation of the wave board drives distributed across single clusters. Picture 1 shows the plant structure consisting of overall nine clusters.

Each cluster (picture 2) is controlled by a Cannon-Automata A2-PAC controller. The eight drives for moving the wave boards are connected to its integrated Sercos master interface. Each of the 72 wave boards has a stroke of 1 m and can be moved with a maximum velocity of 1,000 mm/s. The wave generator, a software module running on the A2-PAC, calculates the velocity command values. The wave generator provides support for active wave absorption for both 2-D and 3-D waves. This is accomplished by measuring the actual wave height along the surface of each wave board using a sensor connected to the CAN interface of the A2-PAC and comparing it to the expected wave height. The active wave absorption method used by Akamina Technologies uses a velocity controller that tracks the desired velocity and the corresponding desired wave height at the same time. When computing the desired velocity of the wave board, the control algorithm looks at the difference between the desired and measured wave height and converts this to a velocity correction. The velocity correction is added to the desired velocity, which the controller then tracks.

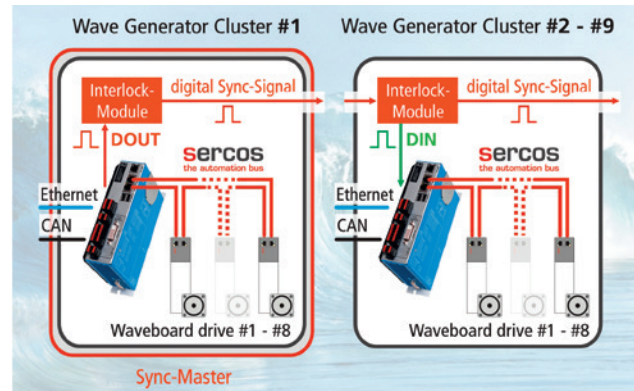

Picture 2: Structure of a drive cluster

For steady wave heights and wave frequency over the whole water basin, an exact synchronization of all 72 wave boards is required. Within a cluster of eight wave boards this is already guaranteed by using Sercos® as a communication system, further effort is not necessary. The challenge of this application was the synchronization of the wave board drives across cluster boundaries. This requirement is solved using an already present Sercos master feature in combination with the A2-PAC onboard I/Os and an electronic board – the so-called interlock module – especially designed for this purpose. A signal clock-synchronous with the Sercos communication cycle of the Sercos master controlling the first cluster sets a digital output of the A2-PAC. The interlock module of the following cluster detects this signal and forwards it directly without time offset to the next cluster. Simultaneously, this synchronization signal is passed on by the interlock module to a digital input of the A2-PAC controller. The onboard logic of the A2-PAC uses this input signal to trigger the communication cycle of the integrated Sercos master without time delay.

This method allows the clock-synchronous operation of multiple Sercos real-time Ethernet networks. It is easy to install and requires no configuration effort. It guarantees a stable and reliable synchronization of complex modular machines and plants.



## Key features of the A2-PAC controller

- Intel® Atom to Core-I CPUs
- Sercos® or Ethercat® Master
- CAN-Bus interface
- Onboard I/Os
- XD-Panel interface